

PITELUMEC

Thumper 125 DOWN THE HOLE HAMMER



THUMPER 125 FOR HOLE DIAMETER 330 - 460MM

PNEUMEC THUMPER 125 12" DOWN THE HOLE HAMMER

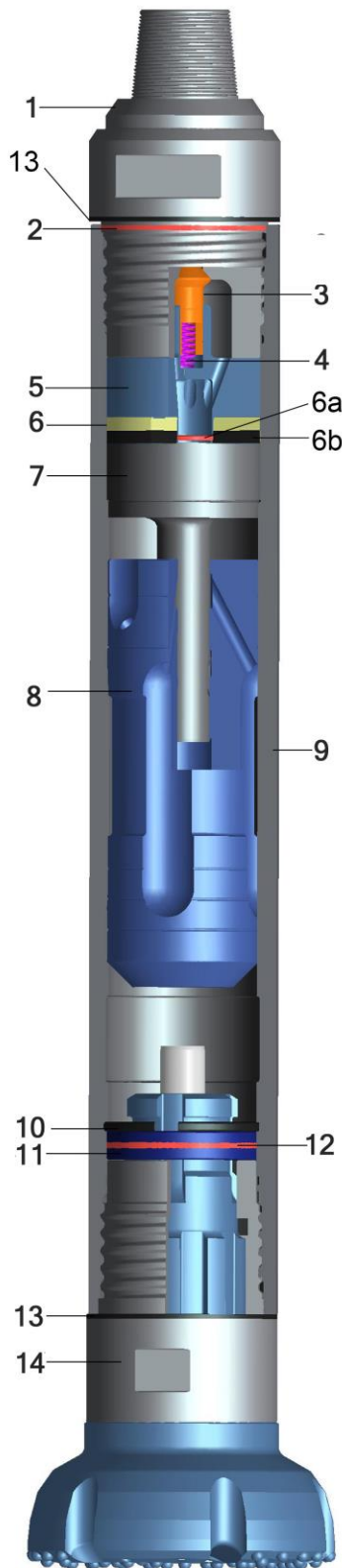

THUMPER 125 HAMMER PARTS LIST

1.	BACKHEAD 6-5/8" API REG PIN	HSP125S1T5M
2.	BACKHEAD "O" RING	HSP125S2
3.	CHECKVALVE	HSP125S3
4.	CHECK VALVE SPRING	HSP125S4
5.	VALVE CHEST	HSP125S5
6.	MAKE UP RING	HSP125S22
6a.	MAKE UP PLATE "O" RING	HSP125S6
6b.	MAKE UP PLATE	HSP125S23
7.	CONTROL TUBE	HSP125S8
8.	PISTON	HSP125S12125
9.	WEARSLEEVE	HSP125S18
10.	PISTON RING	HSP125S25
11.	BIT RETAINERS	HSP125S15125
12.	BIT RETAINER "O" RING	HSP125S16
13.	WASHER (2)	HSP125S21
14.	CHUCK N125	HSP125S19125
15.	COMPLETE HAMMER N125	HAM125125THP

THUMPER 125 HAMMER SPECIFICATIONS

DIAMETER	305MM
LENGTH	1870MM
PISTON WEIGHT	125KG
HAMMER WEIGHT	890KG
HOLE DIAMETER	330MM – 460MM
BACKHEAD CONNECTION	6-5/8" API REG PIN
SHANK TYPE	N125

THUMPER 125 HAMMER AIR CONSUMPTION

PRESSURE (BAR / PSI)	CFM	M ³ /MIN
6.9 / 100	600	17
10.3 / 150	1100	31
13.8 / 200	1600	45
15.2 / 225	2000	56

PNEUMEC

PNEUMEC COMPANY LIMITED

1st Floor, Tin On Sing Comm. Bldg., 41-43 Graham St. Central, H.K.

Tel : (852) 2180 9922

Fax : (852) 2180 9982

Website : www.pneumec.com

email : info@pneumec.com